

# TOSHIBA

## Network Computing Terminal

### General



- The network computing terminal (type name NCT 2000) is equipped with real-time processing and network communication functions in a compact unit.
- Installed in power systems or industrial systems to measure and monitor field information (current, voltage and binary input).
- The network computing terminal performs high-speed data sampling and high-precision time-tagging synchronized by GPS.
- Users can access the field data through LAN or Internet and view the data using standard browser software such as Netscape Navigator® and Internet Explorer®.
- Network interface and software platform support various system applications.

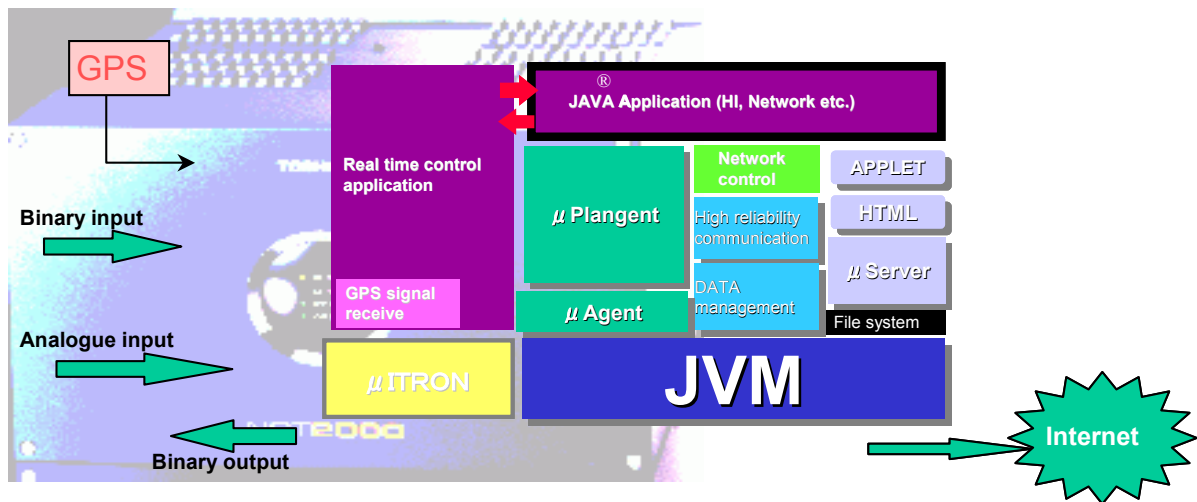

Keyword: Internet, Intranet, IP, IT, GPS, Monitoring, Phasor, Fault Locator (FL), agent

# TOSHIBA

## Feature

### Real-time measuring and monitoring of the analog and digital data

- Input circuit with high-speed sampling rate (2.4 to 28.8 kHz) and 16 bit Analog-to-Digital conversion
- Binary input port for various on/off signal
- High accuracy time-tagging by GPS time synchronization

### Network Application

- Communication interface for LAN (TCP/IP), PC and other equipment
- Access from browser software (IE®, Netscape®, etc.) via network
- Applicable to internet / intranet as Web server
- Platform for various application using HTML, Applet and Agent
- Installed in an existing stand-alone system to be "On-Line Terminal"

### Power and Industrial System Application

- Withstand severe electromagnetic field (conform to IEC Standards)
- Remote access to field information from Control Center
- On-line / Real-time monitoring of Power quality (voltage, frequency, etc.)

# TOSHIBA

## Application

### EXAMPLE 1: Remote Monitoring System

The figure below shows an application example of the Network Computing Terminal with various inputs interfaces and Web-server function. A Personal computer (PC) with common browser can display data stored in the network computing terminal as a form of list or figures by accessing to it. Control command can be sent from the PC. It has advantages that the user can construct communication network with common items and utilize familiar software as HMI.

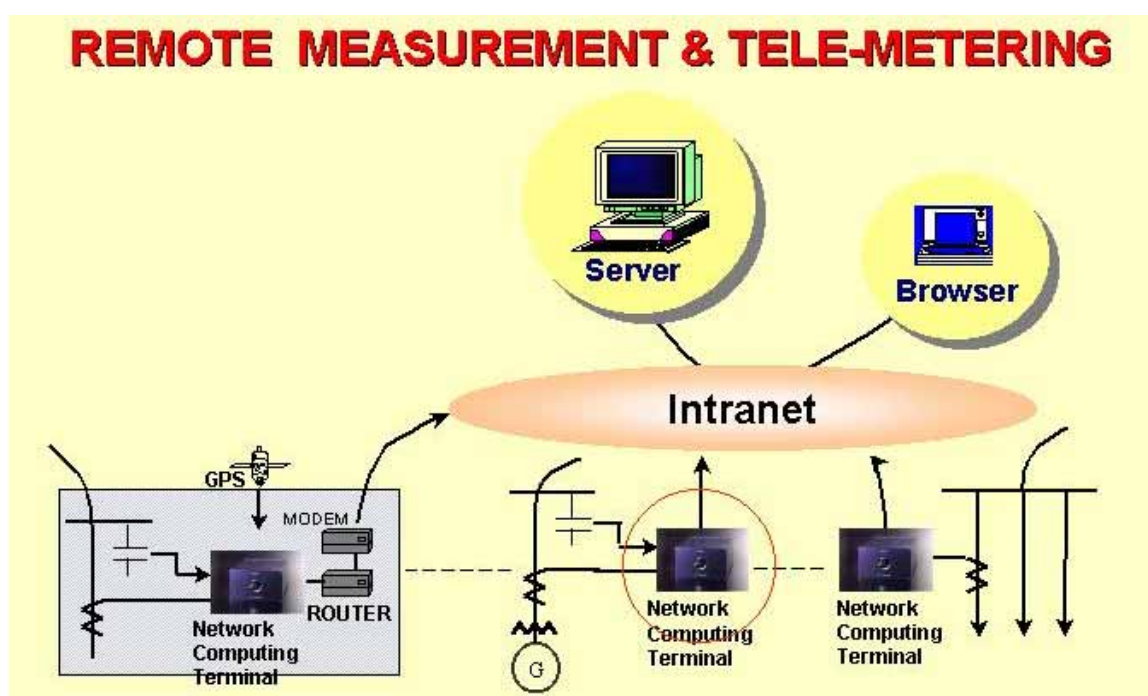

# TOSHIBA

## EXAMPLE 2: Network Fault Locating System

The figure below shows an application system with highly accurate A/D converter, wide-area synchronization function using GPS, real-time calculation function, and network connection function of the Network Computing Terminal. The Network Computing Terminal detects a fault on power systems and stores its pre/post-fault data. The data can be transmitted to a PC as COMTRADE format and the Network Computing Terminal makes advantage of its Java® application and makes it possible to process highly accurate data synchronized with GPS signals.

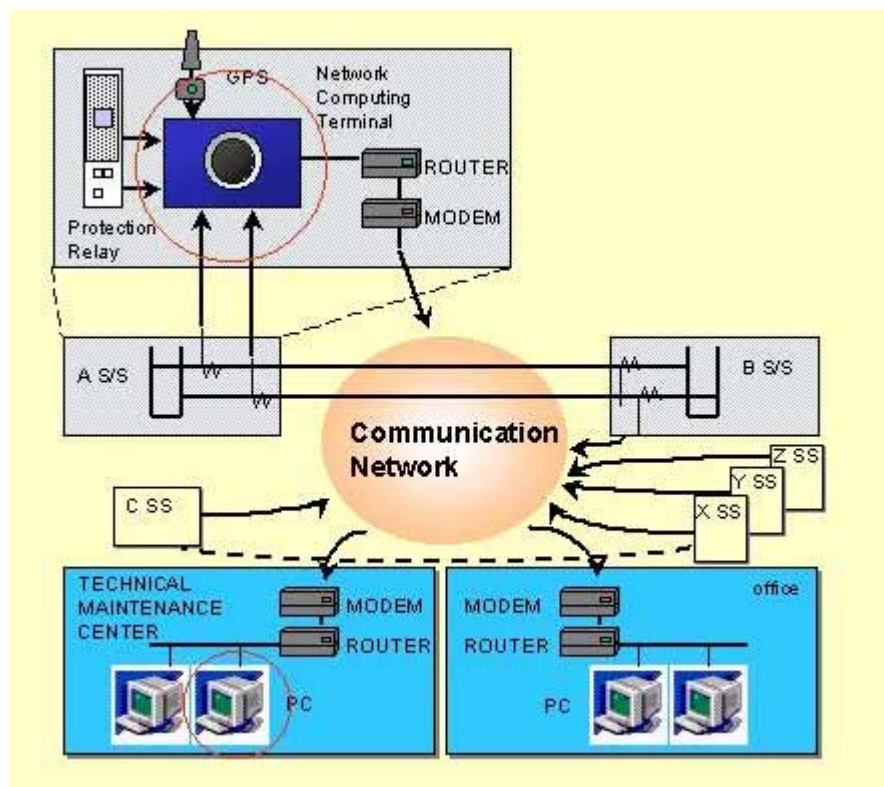

# TOSHIBA

## EXAMPLE 3: Phasor Monitoring System

The figure below shows an application system with highly accurate A/D converter function and wide-area synchronization function utilizing GPS signals. Phase difference of voltages at a remote point can be measured with absolute time signals of the GPS.

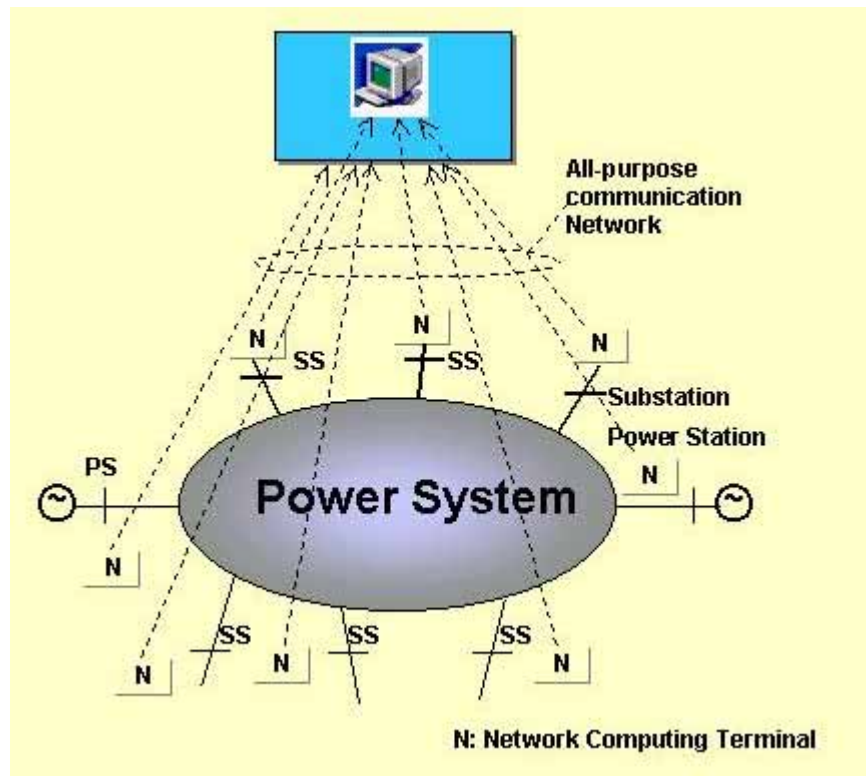

# TOSHIBA

## EXAMPLE 4: Agent Program

This is an application example of automatic fault analysis using an agent program. The Network Computing Terminal incorporates Java® execution environment and it can collect and process information using an agent program when a fault occurs on the power network and the fault information can be displayed on a browser via a server. This system with an agent program transmits not only information but also the program itself. That is, the program which processed data on point A moves to point B and processes data there. This can be achieved on a PC and also on the Network Computing Terminal owing to OS-independent Java®.

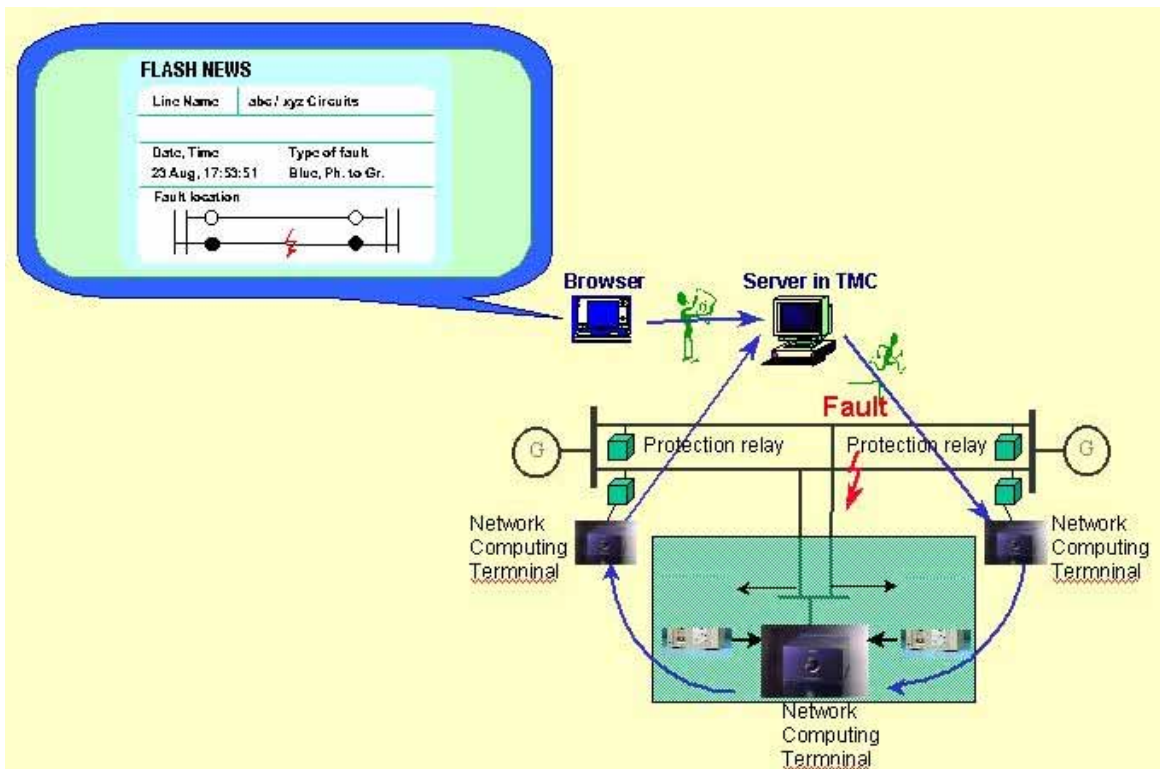

# TOSHIBA

## Technical Data

Model		Type I
Application		for 1cct analog input
Dimension (W x H x D ; mm)		135 x 133 x 245
Weight		5.5kg
Rating	Power supply	DC110V or AC100V
	AC Current	1A / 5A
	AC Voltage	63.5V (PH-N)
Burden	Power supply	< 15W at 110Vdc
	AC Current	< 0.5 VA at rated Current
	AC Voltage	< 0.5 VA at rated Voltage
Frequency		50 / 60 Hz
Atmospheric environment		-10°C to +50°C
Binary Input (DC110V)		19
Analog Input		Current x 4, Voltage x 3
Measurement accuracy		0.5%
Sampling rate		4800 / 5760Hz
Communication interface		GPS: Optical I/F (Input x 1, Output x 1)
		Ethernet: 10Base-T or 10Base-FL (option)
		Isolated RS-232C x 2 (RJ12 connector)
LED Indication		"RUN" (Yellow): In service
		"ERR" (Red): Hardware failure
		"ETH" (Green): Ethernet communication in active
		"GPS" (Green): GPS signal in active
Alarm	Unit failure	N/O x 1
	Power supply failure	N/C x 1
	GPS signal failure	N/O x 1
	Operation	N/O x 1
Memory	RAM	EDO-DRAM with ECC; 32MB
	ROM	Flush ROM; 16MB

# TOSHIBA

## Outline

### Type I

135(W)x133(H)x245(D); mm

#### <Front view>



#### <Rear view>

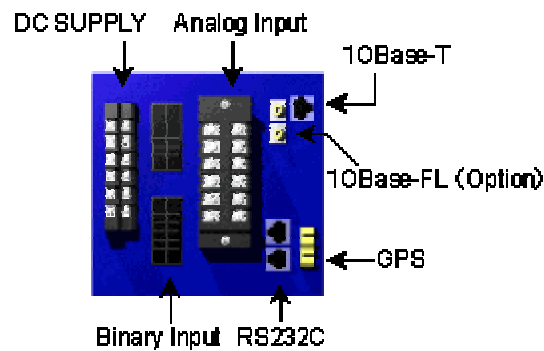

---

Trademarks used in this text: *Java* is registered trademark of Sun Microsystems corporation; *Microsoft*, *Internet Explorer* is registered trademark of Microsoft Corporation; *Netscape Navigator* is registered trademarks of Netscape Communications Corporation. Other trademarks and trade names may be used in this document to refer to either the entities claiming the marks and names of their products. TOSHIBA Corporation disclaims any proprietary interest in trademarks and trade names other than its own.